

Optical Dissolved Oxygen Controller

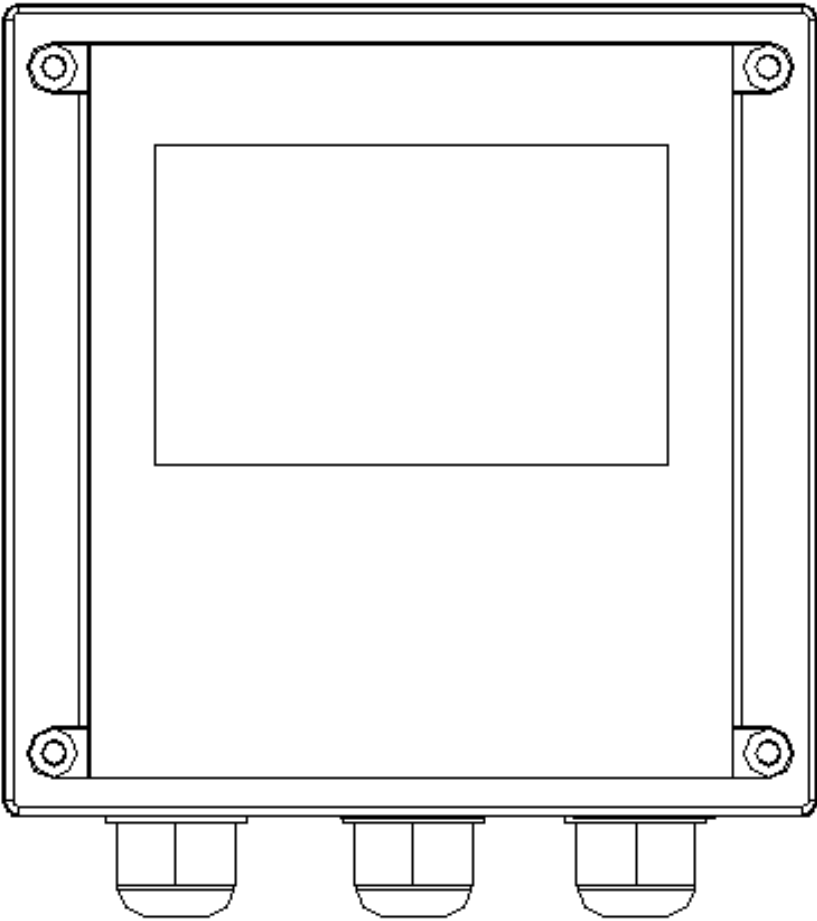

Content

Safe operation procedures-----	2
Instrument use-----	2
Product content-----	2
Specifications-----	3
Instrument installation-----	4
Connection label-----	5
Electrode connection figure-----	5
Relay contact protection -----	6
Display -----	7
Key-----	8
Keeping mode-----	8
Setting-----	9
Current 1 settings-----	10
Current 2 settings-----	10
Relay 1 settings-----	11
Relay 2 settings-----	11
Relay 3 settings-----	12
Measuring settings-----	12
Temperature settings-----	13
RS485 settings-----	13
Date settings-----	13
Data log settings-----	14
Output test-----	14
Language Settings-----	14
Reset the parameters-----	15
Record query-----	15
DO calibration-----	16
Default-----	19
Password-----	20
Error code-----	20
RS485 command-----	20

Safe operation procedures

Read the following instructions before using the instrument.

1. After unpacking the instrument please check for damage due to shipping.
2. The instrument must be operated by trained professional and technical personnel.
3. Read the manual carefully to avoid incorrect wiring connection that can cause equipment damage and safe problem.
4. After wiring carefully check all are correct then can power on and make sure the others equipments are correct.
5. Please avoid installing in a high humidity, high temperature, corrosive and in a direct sunlight environment.
6. Please separate the power lines of instrument from other machines that produces high noise in the power lines.

Instrument use

Instruments are used in industrial measuring of the temperature and DO, such as wastewater treatment, environmental monitoring, drinking water, sea water, food production process, etc.

The instrument can be panel, wall or pipe mounted.

The instrument provides two current outputs. The maximum load is 500 Ohm.

The instrument provides 3 relays. It can pass though a maximum of 5 Amps at 250 VAC or 5 Amps at 30VDC.

Product content

The product package contains 1 instrument, the printed manual, 4 sets of brackets.(fixed block, fixed bar, screw)

Specifications

Functions	%sat	ppm mg/L
Measuring range	0.0 to 200.0	0.00 to 20.00
Resolution	0.1	0.01
Accuracy	±0.2	±0.02
Temp. compensation	NTC	
Temp. range	0.0 to +50.0°C	
Temp. compensation range	0.0 to +50.0°C	
Temp. resolution	0.1°C	
Temp. accuracy	±0.2°C	
Pressure range	0 to 2100 mBar	
Salinity range	0.00 to 50.00 ppt	
Reading refresh	5-60 second	
Ambient temperature range	0 to +70°C	
Storage temp.	-20 to +70°C	
Display	Back light, dot matrix	
DO current output1	Isolated, 4 to 20mA output , max. load 500Ω	
Temp. current output 2	Isolated, 4 to 20mA output , max. load 500Ω	
Current output accuracy	±0.05 mA	
RS485	Modbus RTU protocol	
Baud rate	9600/19200/38400	
Maximum relay contacts capacity	5A/250VAC,5A/30VDC	
Cleaning setting	ON: 1 to 1000 seconds, OFF: 0.1 to 1000.0 hours	
One multi function relay	clean/period alarm/error alarm	
Relay delay	0-120 seconds	
Data logging capacity	500,000	
Language selection	English/traditional Chinese/simplified Chinese	
Waterproof grade	IP65	
Power supply	From 90 to 260 VAC, power consumption < 5 watts	
Installation	panel/wall/pipe installation	
Instrument size	144mm X 144mm X 105mm (H/W/D)	
Cutout size	138mm X 138mm	
Weight	0.85Kg	

Instrument installation

The instrument can be panel, wall or pipe mounted installation.

Panel Installation: Make a 138x138 mm square cutout and insert the instrument. Screw in the fixed block with the screws and fixed bar.

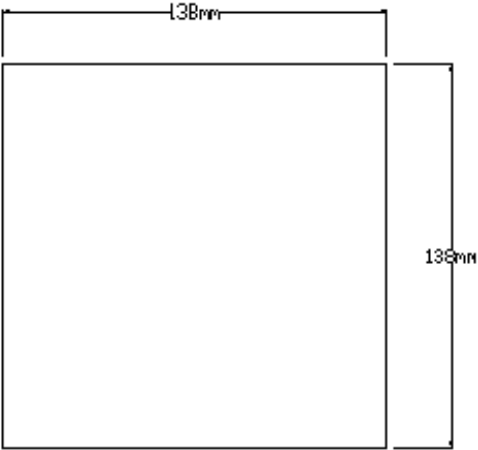

Cutout size

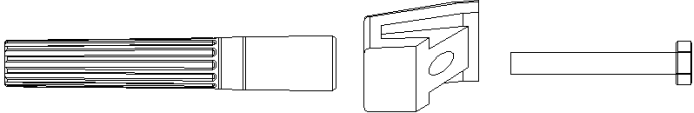
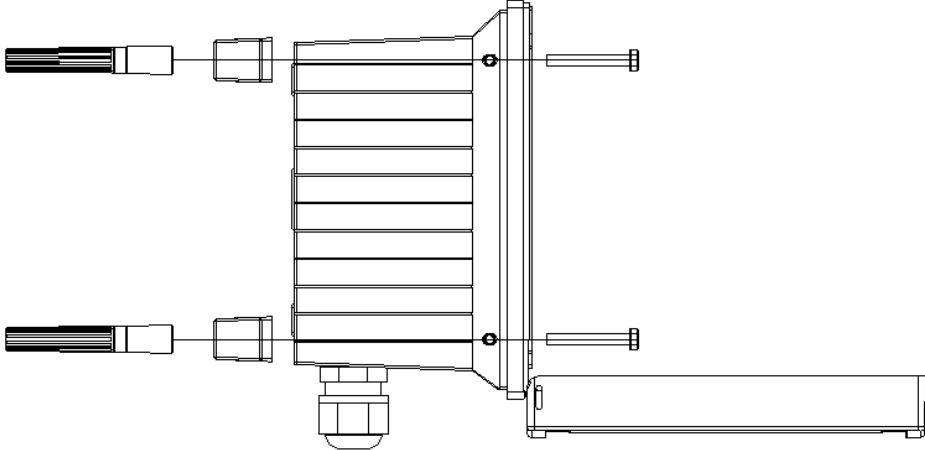
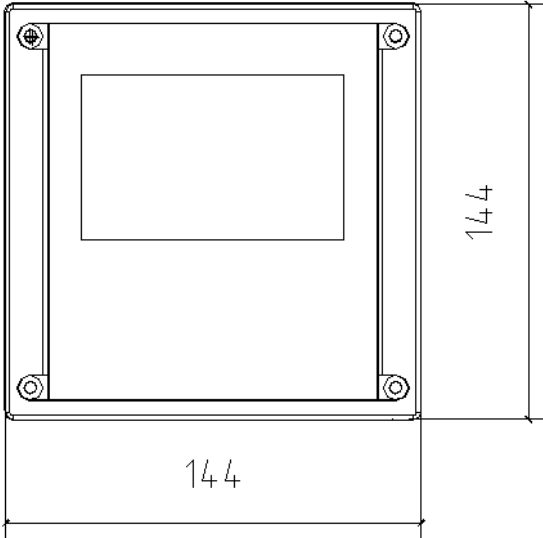

Installation figure

Wall and pipe installation

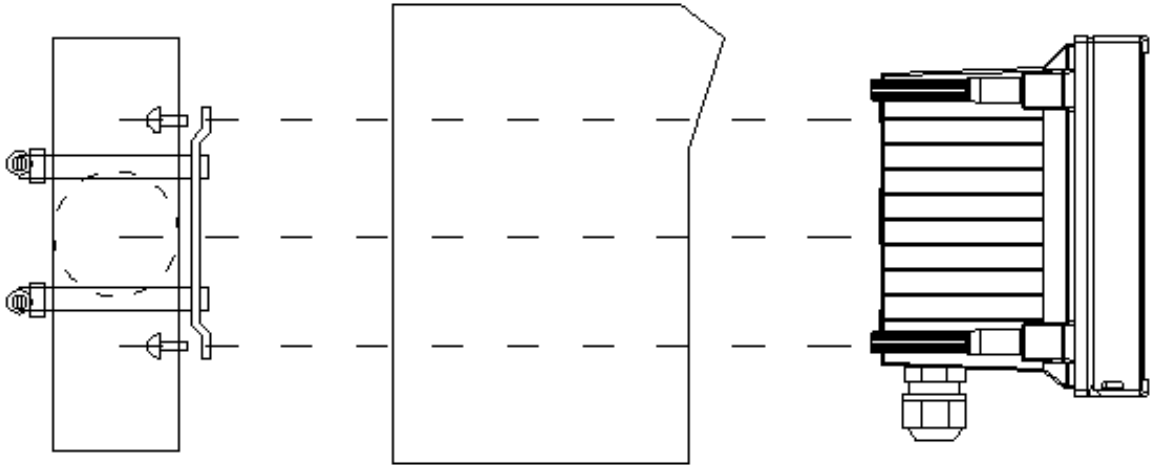

Connection label

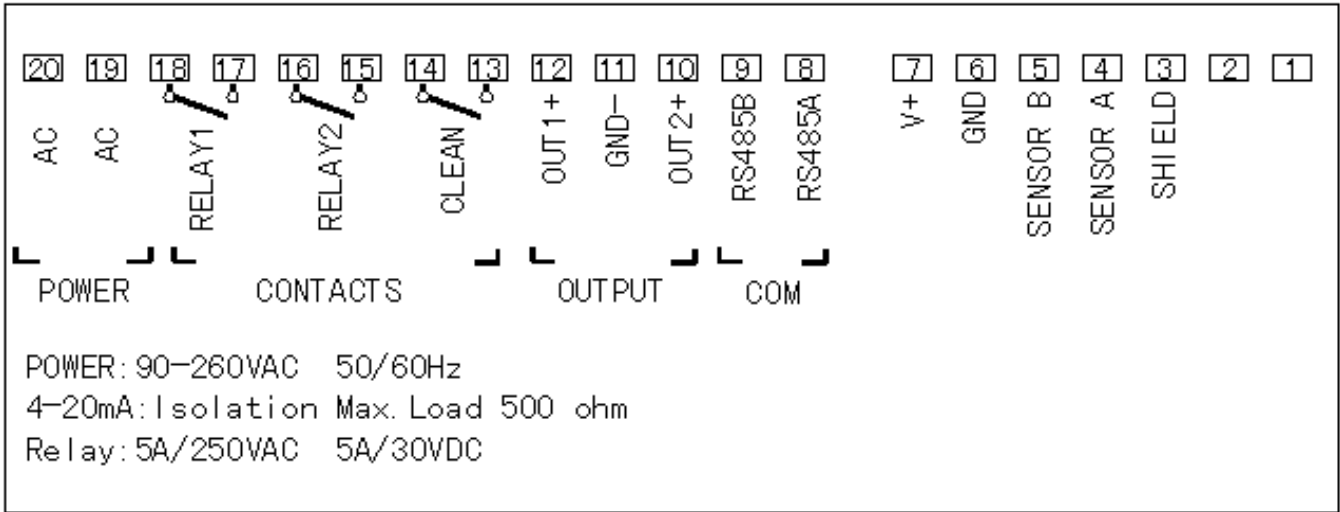

Electrode connection figure

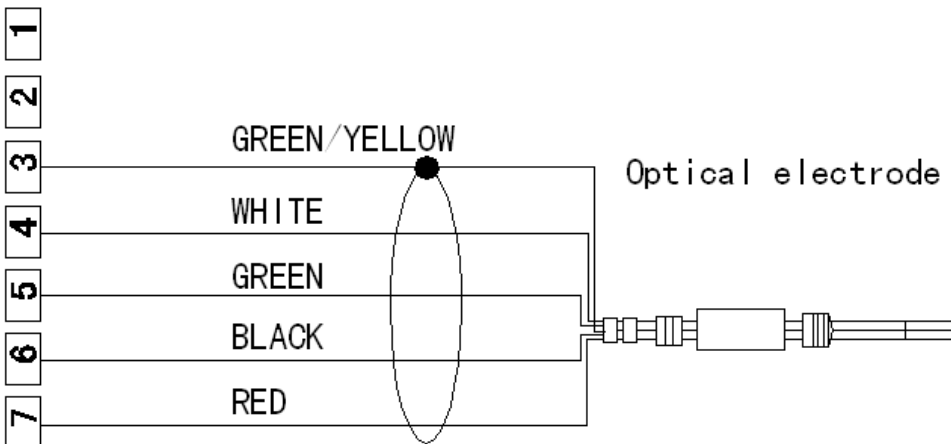

Relay contact protection

Electrical spark at the relay contact may affect the life of the relay, especially in an inductive and capacitive load. In order to inhibit the spark and arc, user should use an RC circuit to extend the life of the relay.

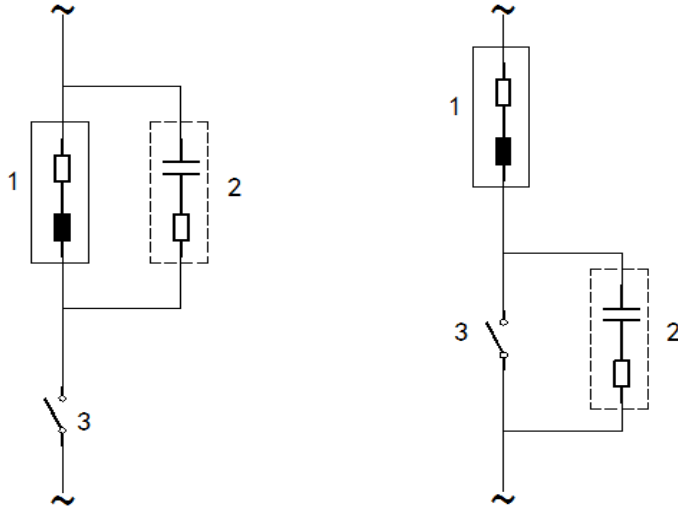

AC protection, use for inductive load

1. load
2. RC eliminate spark, using in 220VAC, $R=100\ \text{ohm}1\text{W}$,
3. Relay contact

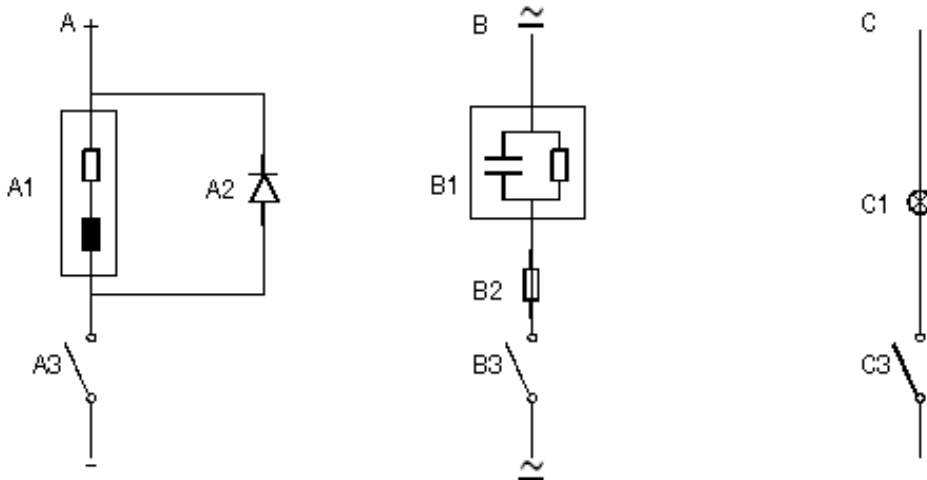

- A. DC protection ,A1: inductive load A2: 1N4007, A3: relay contact
- B. AC/DC protection ,B1: capacitive load ,B2: 0.8 Ohm/1W (DC24V) ,B3: relay contact
- C. Resistive load ,C1:lamp bulb ,C3:relay contact

Display

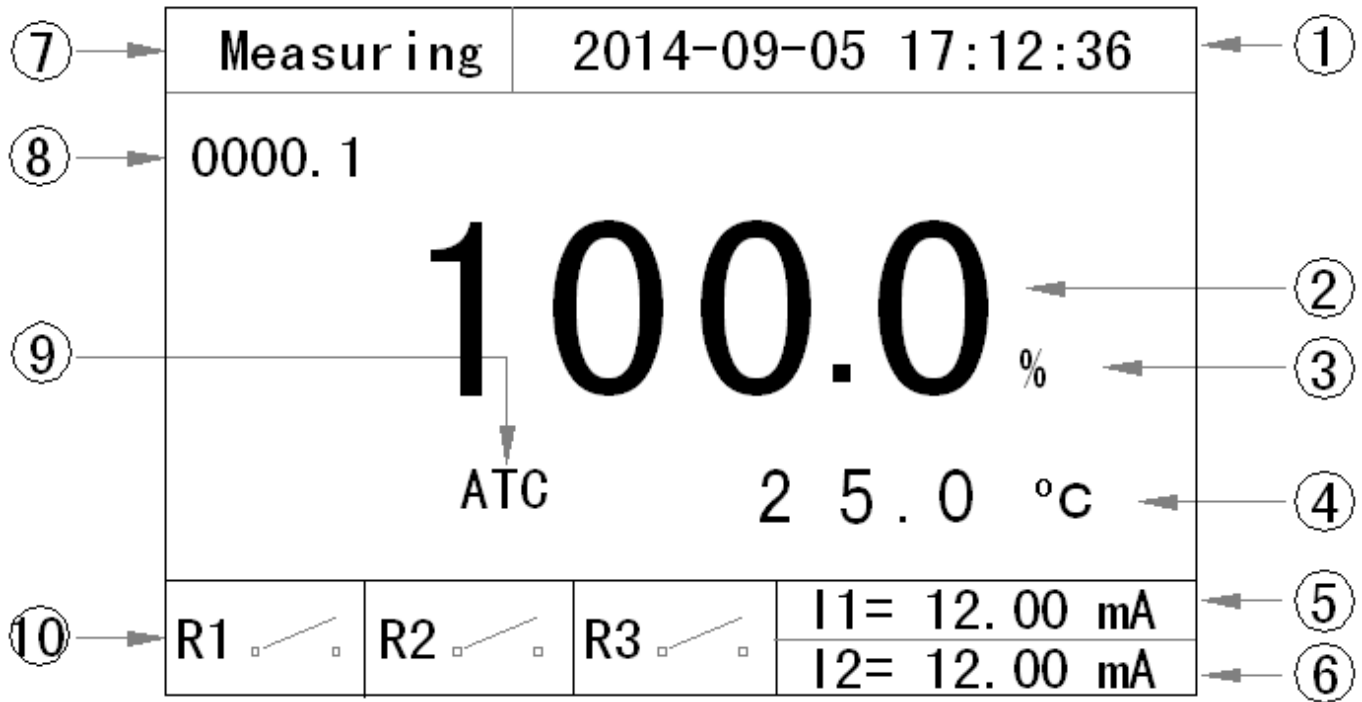

1. Date and time
2. Main display
3. Unit
4. Temperature and unit
5. First current output
6. Second current output
7. Measurement status and Error indicator, there is no display if meter is in keeping mode
8. Count down timer: cycle time/clean time, it also displays the “delay” when relay3 has a delay enabled.
9. Temp. compensation: auto(ATC)
10. Relay indicator

Key

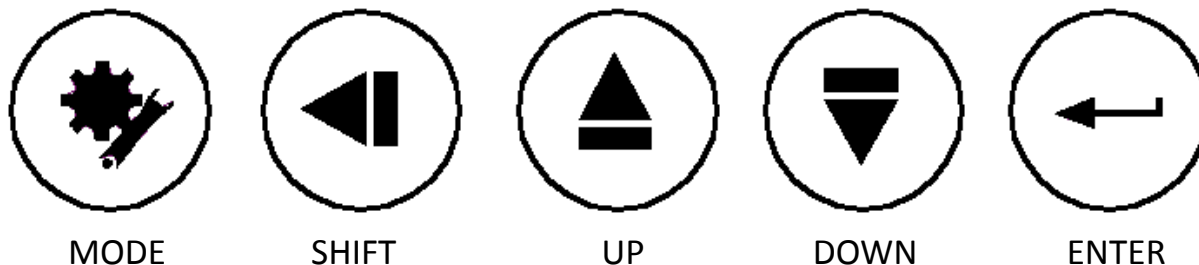

Key name	Meas. status	Setting status	Cal. status	Record status
MODE	Enter password	Exit	Exit	Exit
SHIFT	none	Move digit	Mode digit	Mode digit
UP	Enter record	Inc	Inc	Inc
DOWN	None	Dec	Dec	Dec
ENTER	ON/OFF back light	Enter	Enter	Enter

Keeping mode

Keeping mode is a safe mode. It is for Calibration, Setting, Record and Clean. In this mode all the relays are open(inactive), current output follows the setting by user(last current or fixed current).

The instrument will enter keeping mode when user presses into Calibration, Setting, Record or the instrument works in clean mode.

It will in keeping mode around 10 seconds when it goes back to measurement mode form the above mentioned 4 mode then left keeping mode.

The instrument will go into the keeping mode when turn on the power.

Current output in keeping mode:

User has two choices: fixed current output or last current output.

Fixed current: User can set the output current from 4.00 to 20.00mA when instrument goes into keeping mode.

Last current: User can set the output current keep at the last current when instrument goes into keeping mode.

Relays in keeping mode: Relay1 and Relay2 open.(inactive)

Setting

Press MODE key to enter the password menu and then press UP/DOWN/SHIFT key to input password 1200 then press ENTER will enter to setting mode or press MODE key to exit. If no key is be pressed and over 10 minutes then it will go back to measurement mode.

PASSWORD
0 0 0 0

PASSWORD
1 2 0 0

Main display

Press UP/DOWN key to choose functions, press ENTER key enter the function.

CONF I G U R A T I O N
<input checked="" type="checkbox"/> Current1 Settings
<input type="checkbox"/> Current2 Settings
<input type="checkbox"/> Relay1 Settings
<input type="checkbox"/> Relay2 Settings
<input type="checkbox"/> Relay3 Settings
<input type="checkbox"/> Measurement Settings
<input type="checkbox"/> Temperature Settings
<input type="checkbox"/> RS485 Settings

Page1

CONF I G U R A T I O N
<input checked="" type="checkbox"/> Date Settings
<input type="checkbox"/> Data Log Settings
<input type="checkbox"/> Output Test
<input type="checkbox"/> Language Settings
<input type="checkbox"/> Reset Parameters

Page2

Notices:

1. When the input data is not in correct range then it will display ERROR on the top of LCD
2. After input data user needs to press ENTER to save the data.
3. Press MODE to exit.
4. No key is be pressed in 10 minutes then it will go back to measurement mode.

Current 1 settings

CURRENT 1 SETTINGS	
4.00 mA	= 000.0 %
20.00 mA	= 100.0 %
Offset	= +0.00 mA
Filter Time	= 000 SEC
HOLD Type	= <input type="checkbox"/> Fixed 04.00 mA <input type="checkbox"/> Last

CURRENT 1 SETTINGS	
4.00 mA	= 00.00 mg/L
20.00 mA	= 10.00 mg/L
Offset	= +0.00 mA
Filter Time	= 000 SEC
HOLD Type	= <input type="checkbox"/> Fixed 04.00 mA <input type="checkbox"/> Last

1. Set the corresponding 4.00mA to %,ppm,mg/L.
2. Set the corresponding 20.00mA to %,ppm,mg/L, the difference between 4.00mA and 20.00 mA at least for % is 10.0, for ppm,mg/L is 1.00.
3. Set the offset current of %,mg/L,the range is ± 1.00 mA.
4. The filter time range is 0-120 seconds, the low pass filter of software will active when the current from one point to another point if user sets the filter time.
5. Set the current 1 output mode(fixed / last) when instrument enter into keeping mode.

Current 2 settings

CURRENT 2 SETTINGS	
4.00 mA	= 00.0 °C
20.00 mA	= 50.0 °C
Offset	= +0.00 mA
Filter Time	= 000 SEC
HOLD type	= <input type="checkbox"/> Fixed 04.00 mA <input type="checkbox"/> Last

1. Set the corresponding 4.00mA to temperature.
2. Set the corresponding 20.00mA to temperature, the difference at least between 4.00mA and 20.00 mA is 10.0°C.
3. Set the offset current of temperature, the range is ± 1.00 mA.
4. The filter time range is 0-120 seconds, the low pass filter of software will active when the current from one point to another point if user sets the filter time.
5. Set the current 2 output mode(fixed / last) when instrument enter into keeping mode.

Relay 1 settings

RELAY 1 SETTINGS	
ON/OFF	= <input checked="" type="checkbox"/> ON = <input type="checkbox"/> OFF
Close S. P.	= 0 8 0 . 0 %
Open S. P.	= 0 2 0 . 0 %
Delay Time	= 0 0 0 SEC

RELAY 1 SETTINGS	
ON/OFF	= <input checked="" type="checkbox"/> ON = <input type="checkbox"/> OFF
Close S. P.	= 0 8 . 0 0 mg/L
Open S. P.	= 0 2 . 0 0 mg/L
Delay Time	= 0 0 0 SEC

1. Press UP/DOWN key to ON/OFF (enable/disable) relay1.
 2. Close set point: active point for %,ppm,mg/L.
 3. Open set point: inactive point for %,ppm,mg/L.
 4. Delay time: the range is 0-120 seconds. Relay needs to delay first then active if the measuring data is reach to close set point.
- Ex: If user wants turn on the pump at 80.0% and turn off it at 20.0%, then the close S.P. needs to set to 80.0%, Open S.P. sets to 20.0%.

Relay 2 settings

RELAY 2 SETTINGS	
ON/OFF	= <input checked="" type="checkbox"/> ON = <input type="checkbox"/> OFF
Close S. P.	= 0 2 0 . 0 %
Open S. P.	= 0 8 0 . 0 %
Delay Time	= 0 0 0 SEC

RELAY 2 SETTINGS	
ON/OFF	= <input checked="" type="checkbox"/> ON = <input type="checkbox"/> OFF
Close S. P.	= 0 2 . 0 0 mg/L
Open S. P.	= 0 8 . 0 0 mg/L
Delay Time	= 0 0 0 SEC

1. Press UP/DOWN key to ON/OFF (enable/disable) relay2.
 2. Close set point: active point for %,ppm,mg/L.
 3. Open set point: inactive point for %,ppm,mg/L.
 4. Delay time: the range is 0-120 seconds. Relay needs to delay first then active if the measuring data is reach to close set point.
- Ex: If user wants turn on the pump at 20.0% and turn off it at 80.0%, then the close S.P. needs to set to 20.0%, Open S.P. sets to 80.0%.

Relay 3 settings

RELAY 3 SETTINGS	
ON/OFF	= <input checked="" type="checkbox"/> ON = <input type="checkbox"/> OFF
Period Time	= 0 0 0 1 . 0 HOUR
Clean Time	= 0 0 1 0 SEC
Delay Time	= 0 0 0 SEC
Function	= <input type="checkbox"/> Rinsing <input type="checkbox"/> Interval Alarm <input type="checkbox"/> Error Alarm

1. Press UP/DOWN key to ON/OFF (enable/disable) relay3.
2. Period time: The period for Rinsing or interval function.
3. Clean time: When period is timeout then relay active.
4. Delay time: the range is 0-120 seconds. Relay needs to delay first then active if the period is timeout.
5. Function: press UP/DOWN key to choose

Rinsing/Interval/Error.

Notice:

1. Rinsing: when period timeout then clean-relay will active, when clean time is timeout the repeat count for the period.
2. Interval alarm: When period timeout then clean-relay active until user resets the interval then the clean-relay inactive and repeat count for the period.
3. Error alarm: The clean-relay active when there is a error produce. No delay time function in this mode.

Measurement settings

MEASUREMENT SETTINGS	
Mode	= <input checked="" type="checkbox"/> % <input type="checkbox"/> ppm <input type="checkbox"/> mg/L
Offset	= + 0 0 %
Filter	= 0 1
Meas. Peri.	= 0 5 SEC

MEASUREMENT SETTINGS	
Mode	= <input type="checkbox"/> % <input type="checkbox"/> ppm <input checked="" type="checkbox"/> mg/L
Offset	= + 0 . 0 0 mg/L
Filter	= 0 1
Meas. Peri.	= 0 5 SEC

1. Choose the mode for measuring, press UP/DOWN key to choose.
2. Offset , range for % is ± 10.0 ,for ppm,mg/L is ± 1.00 .
3. Filter: Range 0-10.

Notice:

If the reading is not stable then user can set the filter to average the readings.

Temperature settings

TEMPERATURE SETTINGS	
Offset	= + 0 . 0 °C
Display	= <input type="checkbox"/> YES <input checked="" type="checkbox"/> NO

1. Temperature offset ,the range is $\pm 5.00^{\circ}\text{C}$.
2. Temperature display: display the temperature on measurement mode or not.

RS485 settings

RS485 SETTINGS	
ID Address	= 0 0 1
Baudrate	= <input type="checkbox"/> 9600 = <input type="checkbox"/> 19200 = <input type="checkbox"/> 38400

1. ID address: 1-255.
2. Baud rate ,press UP/DOWN key to choose.

Date settings

DATE SETTINGS	
Year	= 2 0 1 5
Month	= 0 8
Day	= 1 5
Hour	= 1 3
Minute	= 3 6
Second	= 0 4

Press UP/DOWN key to set the date. When power off the date will be kept for around 2 days.

Data log settings

DATA LOG SETTINGS	
ON/OFF	= <input checked="" type="checkbox"/> ON <input type="checkbox"/> OFF
Display Type	= <input type="checkbox"/> Record <input type="checkbox"/> XY Chart
Reset Record	= <input type="checkbox"/> Yes <input type="checkbox"/> No
Save Period	= 0 6 0 SEC

1. Press UP/DOWN key to ON/OFF (enable/disable) this function.
2. Display type, press UP/DOWN key to choose
3. Erase all the records.
4. Saving period from 5 to 120 second.

Notice:

1. When user chooses ON, then it will save measuring data follow the save period time.
2. Display type: Record, display the detail of record(5 records in one page), XY chart, display a chart.(150 records in one page)
3. When reset the records, it will spend around 10 seconds.

Output test

OUTPUT TEST	
Current1	= 0 4 . 0 0 mA
Current2	= 0 4 . 0 0 mA
Relay1	= <input type="checkbox"/> CLOSE <input type="checkbox"/> OPEN
Relay2	= <input type="checkbox"/> CLOSE <input type="checkbox"/> OPEN
Relay3	= <input type="checkbox"/> CLOSE <input type="checkbox"/> OPEN

1. Current 1 output: 4.00-20.00mA, press UP/DOWN to set.
2. Current 2 output: 4.00-20.00mA, press UP/DOWN to set.
3. Relay 1 output, press UP/DOWN to choose.
4. Relay 2 output, press UP/DOWN to choose.
5. Relay 3 output, press UP/DOWN to choose.

Notice: This function for testing the output only.

Language settings

LANGUAGE SETTINGS	
Language	= <input checked="" type="checkbox"/> English <input type="checkbox"/> 繁體中文 <input type="checkbox"/> 简体中文

Press UP/DOWN key to choose the language.

Reset parameters

RESET PARAMETERS	
Reset Type	= <input checked="" type="checkbox"/> Current
	= <input type="checkbox"/> Relay1
	= <input type="checkbox"/> Relay2
	= <input type="checkbox"/> Relay3
	= <input type="checkbox"/> All

Press UP/DOWN key to choose the reset.

Notice: The reset will not affect the calibrated parameters.

Record query

Press UP key at the measurement mode to enter record query mode.

INPUT RECORD START NUMBER
0 1 0 3 0 0

Press UP/DOWN and SHIFT key to input record number then press ENTER key enter or press MODE key exit.

Display DO record at record

RECORD 0020300		
15-08-14	100.0	%
21:20:49	025.0	°C
15-08-14	100.0	%
21:20:59	025.0	°C
15-08-14	099.9	%
21:21:09	025.0	°C
15-08-14	099.9	%
21:21:19	025.0	°C
15-08-14	100.0	%
21:21:29	025.0	°C

Display DO record at XY chart

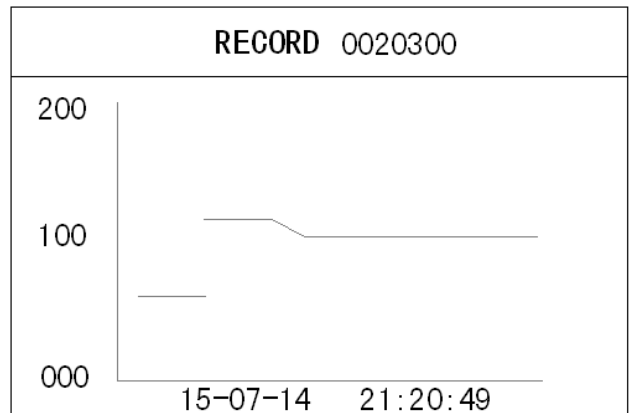

Display ppm record at record

RECORD 0020300		
15-08-14	08.00	ppm
21:20:49	025.0	°C
15-08-14	08.00	ppm
21:20:59	025.0	°C
15-08-14	08.99	mg/L
21:21:09	025.0	°C
15-08-14	08.99	mg/L
21:21:19	025.0	°C
15-08-14	08.00	mg/L
21:21:29	025.0	°C

Display ppm record at XY chart

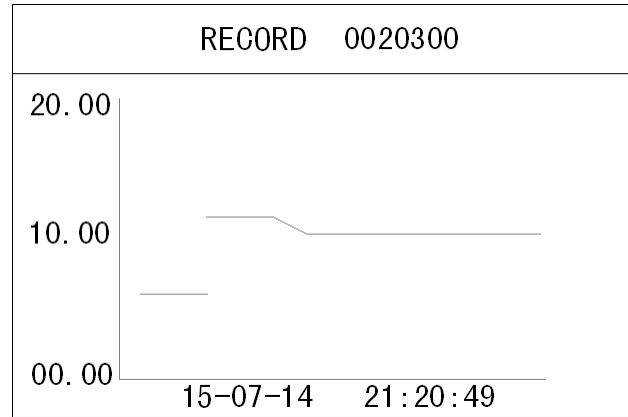

DO Calibration

Press MODE key to enter the password menu and then press UP/DOWN/SHIFT key to input password 1100 then press ENTER will enter to calibration mode or press MODE key to exit. If no key is be pressed and over 10 minutes then it will go back to measurement mode.

PASSWORD
0 0 0 0

PASSWORD
1 1 0 0

Manu

CALIBRATION
<ul style="list-style-type: none"> ■ Parameters Setting □ 1-point Calibration □ 2-point Calibration □ Working Mode

Press UP/DOWN key to select the functions and then press ENTER key to enter.

1. Parameters setting: set the parameters
2. 1-point calibration: calibrate the 100%.
3. 2-point calibration: calibrate the 0% and 100%.
4. Set the working mode..

Parameters setting

PARAMETERS SETTING	
Pressure	= 1 0 1 3 mBAR
Salinity	= 0 0 . 0 ppt

1. Pressure range is from 0 to 2100 mbar.
2. Press UP/DOWN key to input the salinity.
The range is from 0.0 to 50.0 ppt

1-point calibration

1-point CALIBRATION	
Cal. Value	= 1 0 0 . 0 %
Reading	= 1 0 2 . 0 %

Wait stable and press ENTER

1. Use the calibration bottle(with sponge and water) to calibrate DO in 100%. You can also calibrate in air as your 100% calibration.
2. Waiting for the current is stable then press ENTER to finish the calibration or Press MODE to exit

2-point calibration

0% calibration

2-point CALIBRATION	
Cal. Value	= 0.0 %
Reading	= 002.3 %
Wait stable and press ENTER	

1. Put the DO electrode into the nitrogen or saturated solution of anhydrous sodium sulfite.
2. Waiting for the reading is stable then press ENTER to finish the calibration.

100%calibration

2-point CALIBRATION	
Cal. Value	= 100.0 %
Reading	= 101.0 %
Wait stable and press ENTER	

1. Use the calibration bottle(with sponge and water) to calibrate DO in 100%. You can also calibrate in air as your 100% calibration.
2. Waiting for the current is stable then press ENTER to finish the calibration or Press MODE to exit

Working mode

NTU WORKING MODE
<input checked="" type="checkbox"/> Factory Default
<input type="checkbox"/> User Calibration

1. Factory default, restore to the default parameters.
2. User calibration, using the user calibration parameters

Default

DO 20.00mA corresponding	100.0	%	range: 10.0 to 200.0
DO 4.00mA corresponding	0.0	%	range: 0.0 to 190.0 difference : 10.0
ppm 20.00mA corresponding	10.00	ppm	range: 1.00 to 20.00
ppm 4.00mA corresponding	0.00	ppm	range: 0.00 to 19.00 difference : 1.00
Temp. 20.00mA corresponding	50.0	°C	range: 10.0 to 50.0
Temp. 4.00mA corresponding	0.0	°C	range: 0.0 to 40.0 difference : 10.0
Current 1 output offset	0.00	mA	range: +/- 1.00
Current 2 output offset	0.00	mA	range: +/- 1.00
Current 1 filter	0	second	range: 0 to 120
Current 2 filter	0	second	range: 0 to 120
Current 1 fixed output	4.00	mA	range: 4.00 to 20.00
Current 2 fixed output	4.00	mA	range: 4.00 to 20.00
Current 1 HOLD type	fixed		range: fixed/last
Current 2 HOLD type	fixed		range: fixed/last
Relay 1 DO close S.P.	80.0	%	range: 0.0 to 200.0
Relay 1 DO open S.P.	20.0	%	range: 0.0 to 200.0 difference : 0.1
Relay 1 ppm close S.P.	8.00	ppm	range: 0.00 to 20.00
Relay 1 ppm open S.P.	2.00	ppm	range: 0.00 to 20.00 difference : 0.01
Relay 1 delay time	0	second	range: 0 to 120
Relay 2 DO close S.P.	20.0	%	range: 0.0 to 200.0
Relay 2 DO open S.P.	80.0	%	range: 0.0 to 200.0 difference : 0.1
Relay 2 ppm close S.P.	2.00	ppm	range: 0.00 to 20.00
Relay 2 ppm open S.P.	8.00	ppm	range: 0.00 to 20.00 difference : 0.01
Relay 2 delay time	0	second	range: 0 to 120
Relay 3 period time	1.0	hour	range: 0 to 1000.0
Relay 3 clean time	10	second	range: 0 to 1000
Relay 3 delay time	0		range: 0 to 120
Relay 3 function	error alarm		range: clean/period alarm/ error alarm
Save time	60	second	range: 5 to 120
ID address	1		range: 1 to 255
Baudrate	9600		range: 9600,19200,38400

DO offset	0.0	%	range: +/- 10.0
ppm offset	0.00	ppm	range: +/-1.00
Mode	%		range: %,ppm,mg/L
Temp. Offset	0.0	°C	range: +/- 5.0
Language	English		range: English/tranditional Chinese /simple Chinese
Filter	1		range: 0 to 10
Record type	record		range: record/XY chart
Pressure	1013	mBar	range: 0 to 2100
Salinity	0.0	ppt	range: 0.00 to 50.00
Measuring period	1	Second	range: 5 to 60

Password

Press MODE key

1100:Calibration mode

1200:Setting mode

If no key is be pressed and over 10 minutes then it will go back to measurement mode.

Error code

Error 01	memory error
Error 02	reading is over maximum
Error 03	reading is under minimum
Error 04	temperature is over maximum
Error 05	temperature is under minimum
Error 06	current 1 output is over 20.5 mA,the maximum is 22.00mA
Error 07	current 1 output is under 3.8 mA, the minimum is 3.5mA
Error 08	current 2 output is over 20.5 mA,the maximum is 22.00mA
Error 09	current 2 output is under 3.8 mA, the minimum is 3.5mA
Error 10	record error
Error 11	ADC damage
Error 99	default parameters lost

RS485 command

The instrument use the standard Modbus-RTU protocol, all of the data are word type(2 bytes), the range is -32767~32767 ,16 system.

PC command:

	ID address	command	Start address	Data number	CRC16
length	1 byte	1byte	2 byte	2 byte	2 byte
Ex.	0x01	0x03	0x0001	0x0001	0xD5CA

Instrument response:

	ID address	command	Data number	data	CRC16
length	1 byte	1 byte	1byte	N byte	2 byte
Ex.	0x01	0x03	0x02	0x02 0xBC	0xB895

If response is 01, the command is wrong.

If response is 02, the address is not correct.

If response is 03, data number is not correct.

command 03: read the settings

command 04: read the readings

04:definition

address

(00)	0x00	% / ppm reading	reading:%X 0.1, ppm X 0.01
(01)	0x01	%/ ppm current	reading:X 0.01
(02)	0x02	Temperature	reading:X 0.1
(03)	0x03	Temperature current	reading:X 0.01
(04)	0x04	Error code	reading:X 1
(05)	0x05		
(06)	0x06		
(07)	0x07		
(08)	0x08		
(09)	0x09	Model type	fix to 9

03:definition

Address

(00)	0x00	DO 20.00mA corresponding	reading:X0.1
(01)	0x01	DO 4.00mA corresponding	reading:X0.1
(02)	0x02	ppm 20.00mA corresponding	reading:X0.01
(03)	0x03	ppm 4.00mA corresponding	reading:X0.01
(04)	0x04	Temp. 20.00mA corresponding	reading:X0.1
(05)	0x05	Temp. 4.00mA corresponding	reading:X0.1
(06)	0x06	Current 1 offset	reading:X0.01

(07)	0x07	Current 2 offset	reading:X0.01	
(08)	0x08	Current 1 filter	reading:X1	
(09)	0x09	Current 2 filter	reading:X1	
(10)	0x0A	Current 1 fixed current	reading:X0.01	
(11)	0x0B	Current 2 fixed current	reading:X0.01	
(12)	0x0C	Current 1 HOLD type	reading:X1	0=fixed,1=last
(13)	0x0D	Current 2 HOLD type	reading:X1	0=fixed,1=last
(14)	0x0E	Relay1 DO close S.P.	reading:X0.1	
(15)	0x0F	Relay1 DO open S.P.	reading:X0.1	
(16)	0x10	Relay1 ppm close S.P.	reading:X0.01	
(17)	0x11	Relay1 ppm open S.P.	reading:X0.01	
(18)	0x12	Relay1 delay time	reading:X1	
(19)	0x13	Relay2 DO close S.P.	reading:X0.1	
(20)	0x14	Relay2 DO open S.P.	reading:X0.1	
(21)	0x15	Relay2 ppm close S.P.	reading:X0.01	
(22)	0x16	Relay2 ppm open S.P.	reading:X0.01	
(23)	0x17	Relay2 delay time	reading:X1	
(24)	0x18	Relay3 clean period	reading:X0.1	
(25)	0x19	Relay3 clean time	reading:X1	
(26)	0x1A	Relay3 delay time	reading:X1	
(27)	0x1B	Relay3 function	reading:X1	0:clean,1:period alarm ,2:Error alarm
(28)	0x1C	Record saving time	reading:X1	
(29)	0x1D	Mode	reading:X1	0=%,1=ppm, 2=mg/L
(30)	0x1E	DO offset	reading:X0.1	
(31)	0x1F	ppm offset	reading:X0.01	
(32)	0x20	Temp. offset	reading:X0.1	
(33)	0x21	Language	reading:X1	0=English ,1=traditional Chinese,2=simple Chinese
(34)	0x22	Filter	reading:X1	
(35)	0x23	Pressure	reading:X1	
(36)	0x24	Salinity	reading:X0.1	