

ION Controller

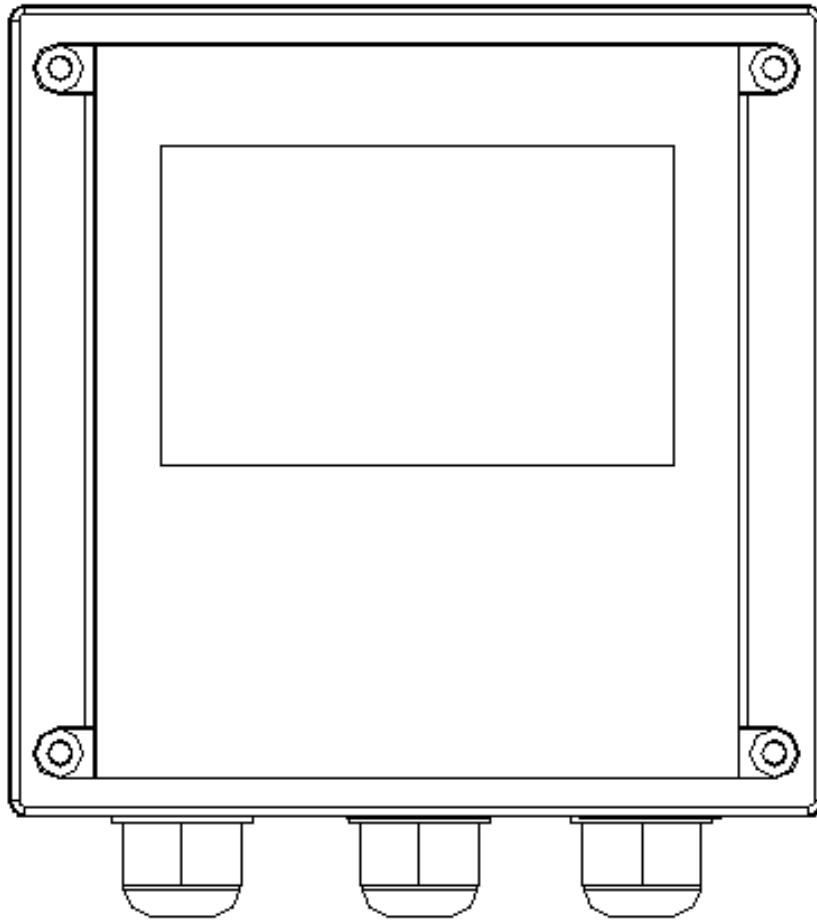

Content

Safe operation procedures-----	2
Instrument use-----	2
Product content-----	2
Specifications-----	3
Instrument installation-----	4
Connection label-----	5
Electrode connection figure-----	6
Relay contact protection -----	7
Display -----	8
Key-----	9
Keeping mode-----	9
Setting-----	10
Current 1 settings-----	11
Current 2 settings-----	11
Relay 1 settings-----	11
Relay 2 settings-----	12
Relay 3 settings-----	12
Measuring settings-----	13
Temperature settings-----	13
RS485 settings-----	14
Date settings-----	14
Data log settings-----	14
Output test-----	15
Language Settings-----	15
Reset the parameters-----	15
Record query-----	16
ION calibration-----	17
Default-----	19
Password-----	20
Error code-----	20
RS485 command-----	20

Safe operation procedures

Read the following instructions before using the instrument.

1. After unpacking the instrument please check for damage due to shipping.
2. The instrument must be operated by trained professional and technical personnel.
3. Read the manual carefully to avoid incorrect wiring connection that can cause equipment damage and safe problem.
4. After wiring carefully check all are correct then can power on and make sure the others equipments are correct.
5. Please avoid installing in a high humidity, high temperature, corrosive and in a direct sunlight environment.
6. Please separate the power lines of instrument from other machines that produces high noise in the power lines.

Instrument use

Instruments are used in industrial measuring of the temperature and ion, such as wastewater treatment, environmental monitoring, electroplate factory, etc.

The instrument can be panel, wall or pipe mounted.

The instrument provides two current outputs. The maximum load is 500 Ohm.

The instrument provides 3 relays. It can pass though a maximum of 5 Amps at 250 VAC or 5 Amps at 30VDC.

Product content

The product package contains 1 instrument, the printed manual, 4 sets of brackets.(fixed block, fixed bar, screw)

Specifications

Functions	ION
Measuring range	0.00 – 20000 ppm
Resolution	0.01(<1ppm), 0.1 (<10ppm), 1(others)
Accuracy	±0.01ppm,±0.1ppm,±1ppm
mV input range	0.00-1000.00mV
Temp. compensation	Pt 1000/NTC10K
Temp. range	-10.0 to +130.0°C
Temp. compensation range	-10.0 to +130.0°C
Temp. resolution	0.1°C
Temp. accuracy	±0.2°C
Ambient temperature range	0 to +70°C
Storage temp.	-20 to +70°C
Input impedance	>10 ¹² Ω
Display	Back light, dot matrix
ION current output1	Isolated, 4 to 20mA output , max. load 500Ω
Temp. current output 2	Isolated, 4 to 20mA output , max. load 500Ω
Current output accuracy	±0.05 mA
RS485	Modbus RTU protocol
Baud rate	9600/19200/38400
Maximum relay contacts capacity	5A/250VAC,5A/30VDC
Cleaning setting	ON: 1 to 1000 seconds, OFF: 0.1 to 1000.0 hours
One multi function relay	clean/period alarm/error alarm
Relay delay	0-120 seconds
Data logging capacity	500,000
Language selection	English/traditional Chinese/simplified Chinese
Waterproof grade	IP65
Power supply	From 90 to 260 VAC, power consumption < 5 watts
Installation	panel/wall/pipe installation
Instrument size	144mm X 144mm X 105mm (H/W/D)
Cutout size	138mm X 138mm
Weight	0.85Kg

Instrument installation

The instrument can be panel, wall or pipe mounted installation.

Panel Installation: Make a 138x138 mm square cutout and insert the instrument. Screw in the fixed block with the screws and fixed bar.

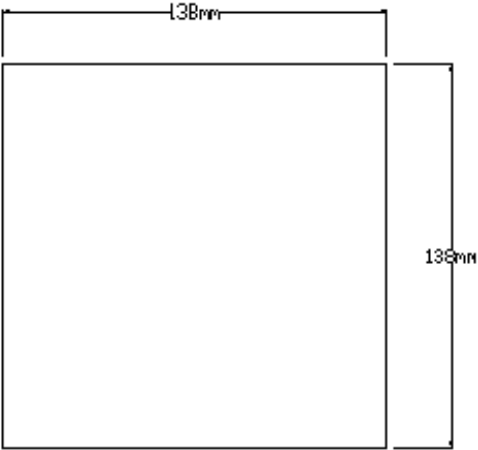

Cutout size

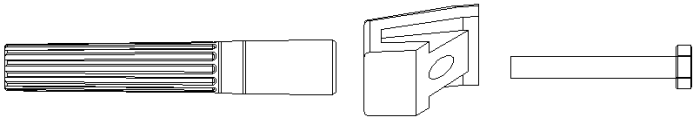
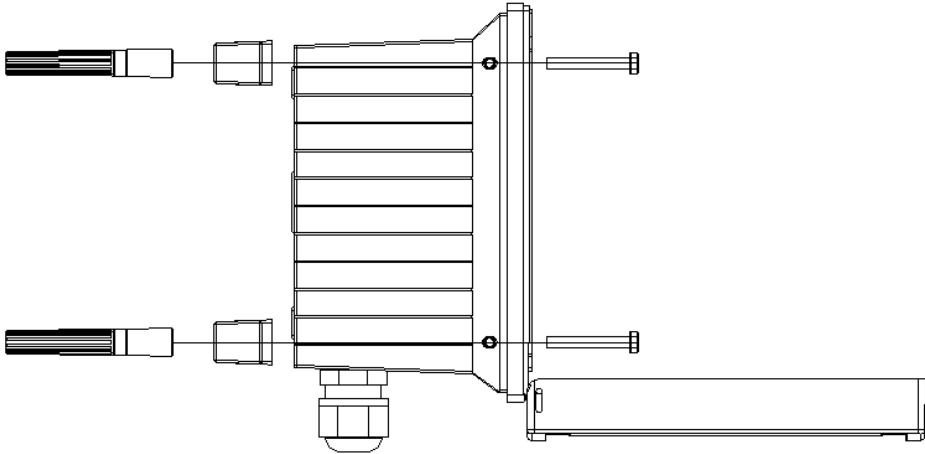
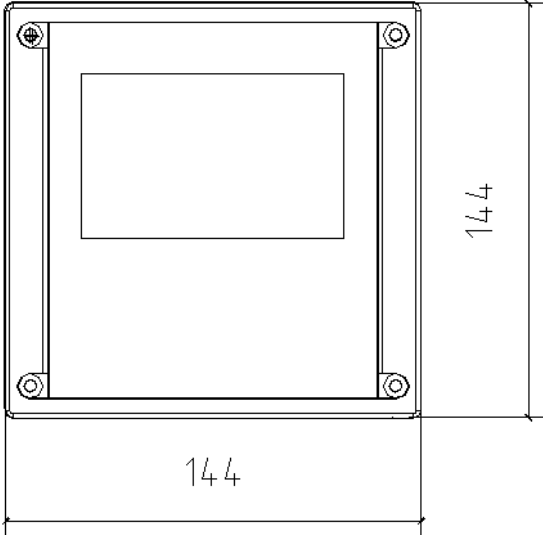

Installation figure

Wall and pipe installation

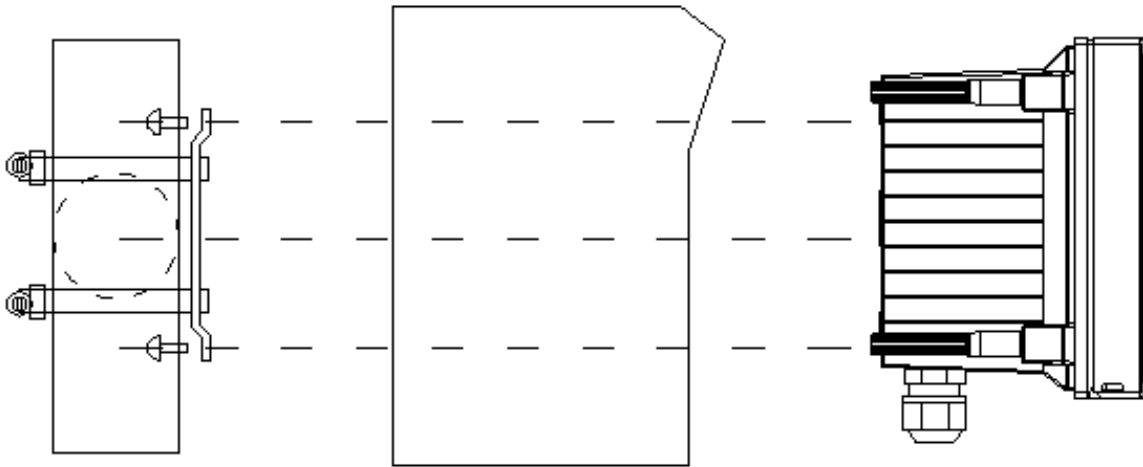

Connection label

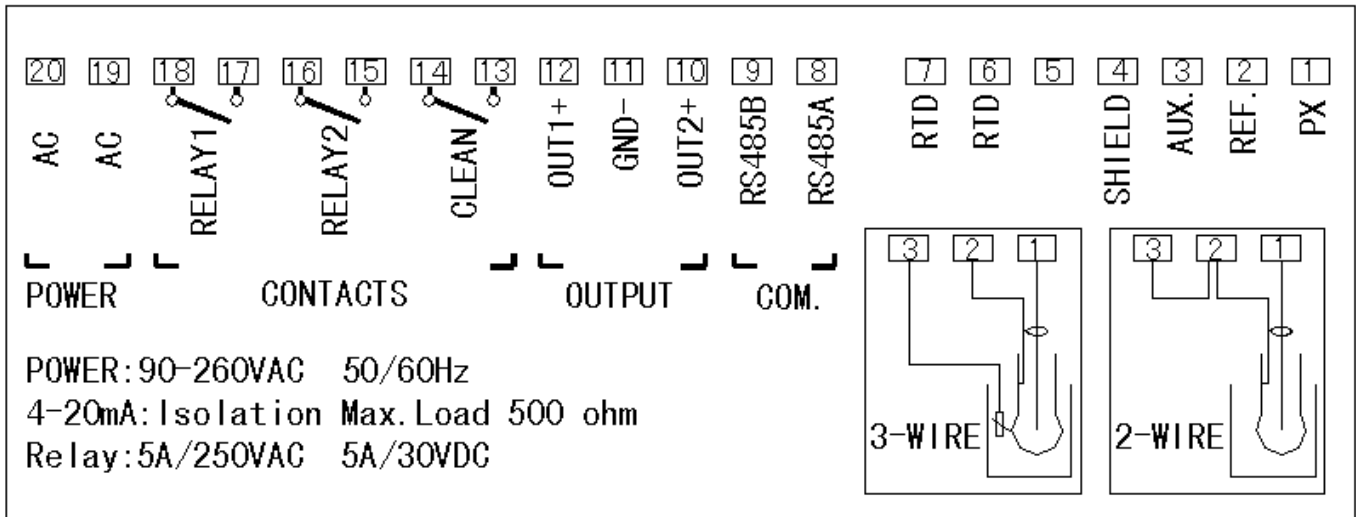

Notice

1. User must strip the ION wire to remove the black rubber conductor.



Rubber conductor not removed



Rubber conductor removed

2. Connection electrode (short pin 2 and 3)

Electrode connection figure

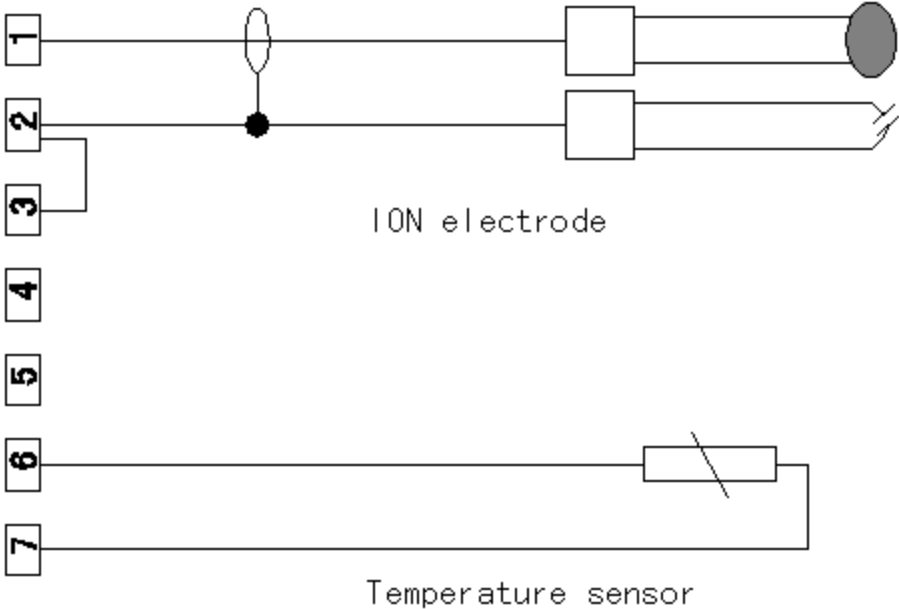

Relay contact protection

Electrical spark at the relay contact may affect the life of the relay, especially in an inductive and capacitive load. In order to inhibit the spark and arc, user should use an RC circuit to extend the life of the relay.

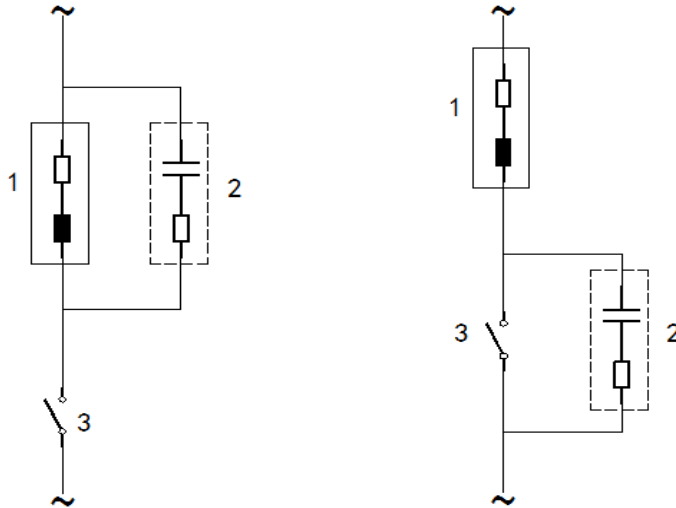

AC protection, use for inductive load

1. load
2. RC eliminate spark, using in 220VAC, $R=100\ \text{ohm}1\text{W}$,
3. Relay contact

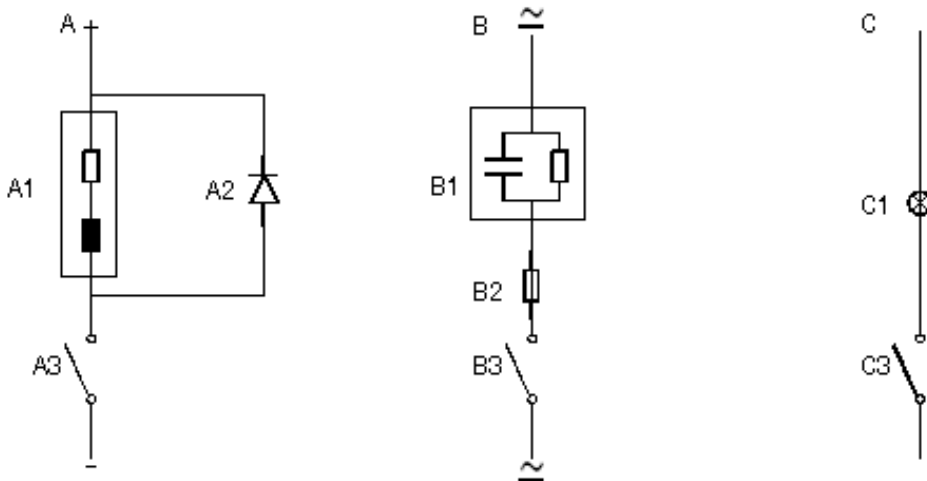

- A. DC protection ,A1: inductive load A2: 1N4007, A3: relay contact
- B. AC/DC protection ,B1: capacitive load ,B2: $0.8\ \text{Ohm}/1\text{W}$ (DC24V) ,B3: relay contact
- C. Resistive load ,C1:lamp bulb ,C3:relay contact

Display

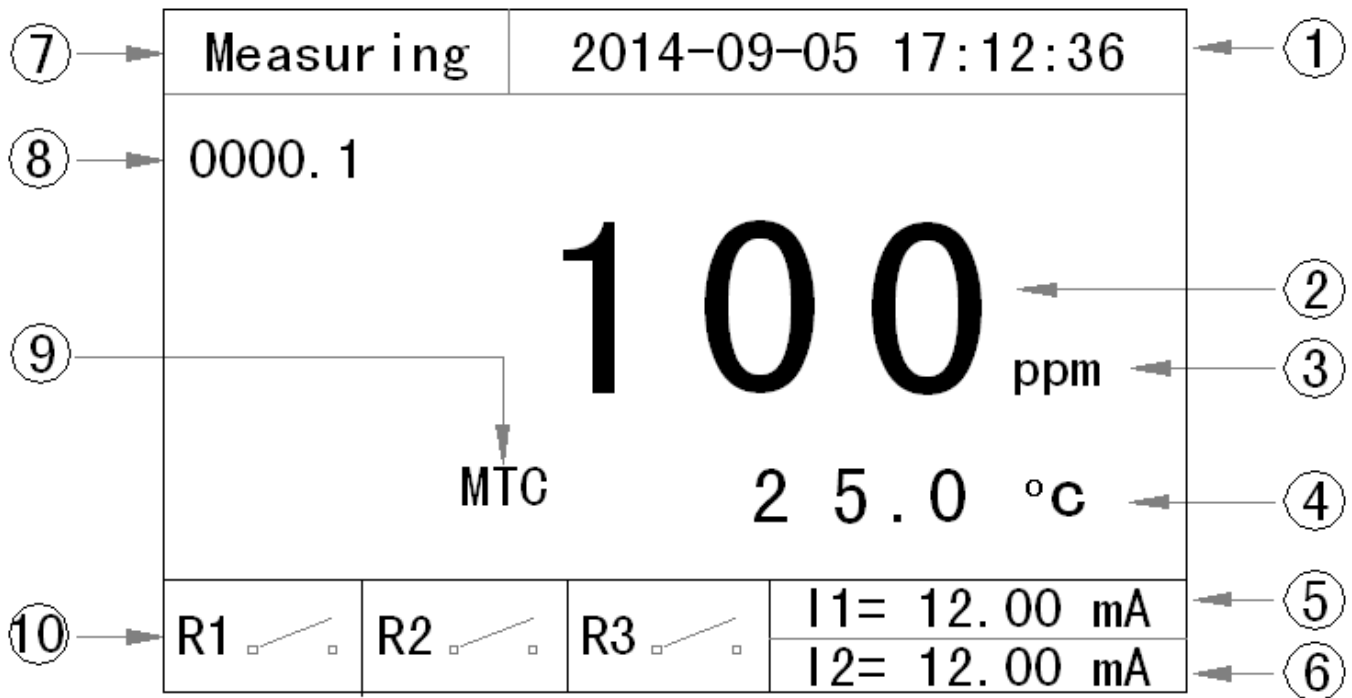

1. Date and time
2. Main display
3. Unit
4. Temperature and unit
5. First current output
6. Second current output
7. Measurement status and Error indicator, there is no display if meter is in keeping mode
8. Count down timer: cycle time/clean time, it also displays the “delay” when relay3 has a delay enabled.
9. Temp. compensation: auto(ATC) or manual(MTC)
10. Relay indicator

Note:

If the ppm readings are under or over the range, it will display 0.00/99999

If the temperature readings are under or over the range, it will display -99.9/999.9.

Key



MODE



SHIFT



UP



DOWN

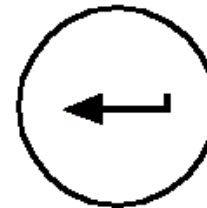

ENTER

Key name	Meas. status	Setting status	Cal. status	Record status
MODE	Enter password	Exit	Exit	Exit
SHIFT	none	Move digit	Mode digit	Mode digit
UP	Enter record	Inc	Inc	Inc
DOWN	None	Dec	Dec	Dec
ENTER	ON/OFF back light	Enter	Enter	Enter

Keeping mode

Keeping mode is a safe mode. It is for Calibration, Setting, Record and Clean. In this mode all the relays are open(inactive), current output follows the setting by user(last current or fixed current).

The instrument will enter keeping mode when user presses into Calibration, Setting, Record or the instrument works in clean mode.

It will in keeping mode around 10 seconds when it goes back to measurement mode form the above mentioned 4 mode then left keeping mode.

The instrument will go into the keeping mode when turn on the power.

Current output in keeping mode:

User has two choices: fixed current output or last current output.

Fixed current: User can set the output current from 4.00 to 20.00mA when instrument goes into keeping mode.

Last current: User can set the output current keep at the last current when instrument goes into keeping mode.

Relays in keeping mode: Relay1 and Relay2 open.(inactive)

Setting

Press MODE key to enter the password menu and then press UP/DOWN/SHIFT key to input password 1200 then press ENTER will enter to setting mode or press MODE key to exit. If no key is be pressed and over 10 minutes then it will go back to measurement mode.

PASSWORD
0 0 0 0

PASSWORD
1 2 0 0

Main display

Press UP/DOWN key to choose functions, press ENTER key enter the function.

CONF I G U R A T I O N
<input checked="" type="checkbox"/> Current1 Settings
<input type="checkbox"/> Current2 Settings
<input type="checkbox"/> Relay1 Settings
<input type="checkbox"/> Relay2 Settings
<input type="checkbox"/> Relay3 Settings
<input type="checkbox"/> Measurement Settings
<input type="checkbox"/> Temperature Settings
<input type="checkbox"/> RS485 Settings

Page1

CONF I G U R A T I O N
<input checked="" type="checkbox"/> Date Settings
<input type="checkbox"/> Data Log Settings
<input type="checkbox"/> Output Test
<input type="checkbox"/> Language Settings
<input type="checkbox"/> Reset Parameters

Page2

Notices:

1. When the input data is not in correct range then it will display ERROR on the top of LCD
2. After input data user needs to press ENTER to save the data.
3. Press MODE to exit.
4. No key is be pressed in 10 minutes then it will go back to measurement mode.

Current 1 settings

CURRENT 1 SETTINGS	
4.00 mA	= 0000 0 ppm
20.00 mA	= 01000 ppm
Offset	= +0.00 mA
Filter Time	= 000 SEC
HOLD Type	= <input type="checkbox"/> Fixed
	04.00 mA
	<input type="checkbox"/> Last

1. Set the corresponding 4.00mA to ppm.
2. Set the corresponding 20.00mA to ppm, the difference between 4.00mA and 20.00 mA at least is 100ppm.
3. Set the offset current of ppm, the range is ± 1.00 mA.
4. The filter time range is 0-120 seconds, the low pass filter of software will active when the current from one point to another

point if user sets the filter time.

5. Set the current 1 output mode(fixed / last) when instrument enter into keeping mode.

Current 2 settings

CURRENT 2 SETTINGS	
4.00 mA	= +000.0 °C
20.00 mA	= +100.0 °C
Offset	= +0.00 mA
Filter Time	= 000 SEC
HOLD Type	= <input type="checkbox"/> Fixed
	04.00 mA
	<input type="checkbox"/> Last

1. Set the corresponding 4.00mA to temperature.
2. Set the corresponding 20.00mA to temperature, the difference at least between 4.00mA and 20.00 mA is 10.0°C.
3. Set the offset current of temperature, the range is ± 1.00 mA.
4. The filter time range is 0-120 seconds, the low pass filter of software will active when

the current from one point to another point if user sets the filter time.

5. Set the current 2 output mode(fixed / last) when instrument enter into keeping mode.

Relay 1 settings

RELAY 1 SETTINGS	
ON/OFF	= <input checked="" type="checkbox"/> ON
	= <input type="checkbox"/> OFF
Close S.P.	= 00100 ppm
Open S.P.	= 00010 ppm
Delay Time	= 000 SEC

1. Press UP/DOWN key to ON/OFF (enable /disable) relay1.
 2. Close set point: active point for ppm.
 3. Open set point: inactive point for ppm.
 4. Delay time: the range is 0-120 seconds. Relay needs to delay first then active if the measuring data is reach to close set point.
- Ex: If user wants turn on the pump at 100ppm and turn off it at 10ppm, then the close S.P. needs to set to 100ppm, Open S.P. sets to 10ppm.

needs to set to 100ppm, Open S.P. sets to 10ppm.

Relay 2 settings

RELAY 2 SETTINGS	
ON/OFF	= <input checked="" type="checkbox"/> ON = <input type="checkbox"/> OFF
Close S.P.	= 00010 ppm
Open S.P.	= 00100 ppm
Delay Time	= 000 SEC

1. Press UP/DOWN key to ON/OFF (enable /disable) relay2.
2. Close set point: active point for ppm.
3. Open set point: inactive point for ppm.
4. Delay time: the range is 0-120 seconds. Relay needs to delay first then active if the measuring data is reach to close set point.

Ex: If user wants turn on the pump at 10ppm and turn off it at 100ppm, then the close S.P.

needs to set to 10ppm, Open S.P. sets to 100ppm.

Relay 3 settings

RELAY 3 SETTINGS	
ON/OFF	= <input checked="" type="checkbox"/> ON = <input type="checkbox"/> OFF
Period Time	= 0001.0 HOUR
Clean Time	= 0010 SEC
Delay Time	= 000 SEC
Function	= <input type="checkbox"/> Rinsing <input type="checkbox"/> Interval Alarm <input type="checkbox"/> Error Alarm

1. Press UP/DOWN key to ON/OFF (enable/disable) relay3.
2. Period time: The period for Rinsing or interval function.
3. Clean time: When period is timeout then relay active.
4. Delay time: the range is 0-120 seconds. Relay needs to delay first then active if the period is timeout.
5. Function: press UP/DOWN key to choose Rinsing/Interval/Error.

Notice:

1. Rinsing: when period timeout then clean-relay will active, when clean time is timeout the repeat count for the period.
2. Interval alarm: When period timeout then clean-relay active until user resets the interval then the clean-relay inactive and repeat count for the period.
3. Error alarm: The clean-relay active when there is a error produce. No delay time function in this mode.

Measurement settings

MEASUREMENT SETTINGS	
Mode	= <input checked="" type="checkbox"/> ppm = <input type="checkbox"/> mV
Offset	= + 0 0 0 ppm
Filter	= 0 0

1. Choose the mode for measuring, press UP/DOWN key to choose.
2. Offset , range is ± 100 ppm.
3. Filter: Range 0-10.

Notice:

If the reading is not stable then user can set the filter to average the readings.

Temperature settings

TEMPERATURE SETTINGS	
Automatic	= <input checked="" type="checkbox"/> Auto = <input type="checkbox"/> Manual
Probe	= <input type="checkbox"/> Pt 1000 = <input type="checkbox"/> NTC 10K
Offset	= + 0 . 0 °C
Manual Meas.	= + 0 2 5 . 0 °C
Manual Cal.	= 2 5 . 0 °C

1. Temperature compensation setting, press UP/DOWN key to choose.
2. Temperature probe, press UP/DOWN key to choose.
3. Temperature offset ,the range is ± 5.00 °C .
4. Temperature for measuring when user sets the temperature to manual.
5. Temperature for calibration mode when user sets the temperature to manual.

TEMPERATURE SETTINGS	
Display	= <input checked="" type="checkbox"/> YES = <input type="checkbox"/> NO

6. Temperature display: display the temperature on measurement mode or not.

Notice:

1. When user chooses AUTO and doesn't connect temperature probe then the display will not correct.
2. When select the probe needs to make sure

the probe type is correct.

3. Manual measurement: the instrument will use this temperature for compensation in measurement mode when user chooses Manual.
4. Manual calibration: the instrument will use this temperature for compensation in calibration mode when user chooses Manual.

RS485 settings

RS485 SETTINGS	
ID Address	= 0 0 1
Baudrate	= <input type="checkbox"/> 9600
	= <input type="checkbox"/> 19200
	= <input type="checkbox"/> 38400

1. ID address:1-255.
2. Baud rate ,press UP/DOWN key to choose.

Date settings

DATE SETTINGS	
Year	= 2 0 1 5
Month	= 0 8
Day	= 1 5
Hour	= 1 3
Minute	= 3 6
Second	= 0 4

Press UP/DOWN key to set the date. When power off the date will be kept for around 2 days.

Data log settings

DATA LOG SETTINGS	
ON/OFF	= <input checked="" type="checkbox"/> ON = <input type="checkbox"/> OFF
Display Type	= <input type="checkbox"/> Record = <input type="checkbox"/> XY Chart
Reset Record	= <input type="checkbox"/> Yes = <input type="checkbox"/> No
Save Period	= 0 6 0 SEC

1. Press UP/DOWN key to ON/OFF (enable/disable) this function.
2. Display type, press UP/DOWN key to choose
3. Erase all the records.
4. Saving period from 5 to 120 second.

Notice:

1. When user chooses ON, then it will save measuring data follow the save period time.
2. Display type: Record, display the detail of record(5 records in one page), XY chart, display a chart.(150 records in one page)
3. When reset the records, it will spend around 10 seconds.

Output test

OUTPUT TEST	
Current1	= 0 4 . 0 0 mA
Current2	= 0 4 . 0 0 mA
Relay1	= <input type="checkbox"/> CLOSE <input type="checkbox"/> OPEN
Relay2	= <input type="checkbox"/> CLOSE <input type="checkbox"/> OPEN
Relay3	= <input type="checkbox"/> CLOSE <input type="checkbox"/> OPEN

1. Current 1 output: 4.00-20.00mA, press UP/DOWN to set.
2. Current 2 output: 4.00-20.00mA, press UP/DOWN to set.
3. Relay 1 output, press UP/DOWN to choose.
4. Relay 2 output, press UP/DOWN to choose.
5. Relay 3 output, press UP/DOWN to choose.

Notice: This function for testing the output only.

Language settings

LANGUAGE SETTINGS	
Language	= <input checked="" type="checkbox"/> English <input type="checkbox"/> 繁體中文 <input type="checkbox"/> 简体中文

Press UP/DOWN key to choose the language.

Reset parameters

RESET PARAMETERS	
Reset Type	= <input checked="" type="checkbox"/> Current <input type="checkbox"/> Relay1 <input type="checkbox"/> Relay2 <input type="checkbox"/> Relay3 <input type="checkbox"/> All

Press UP/DOWN key to choose the reset.

Notice: The reset will not affect the calibrated parameters.

Record query

Press UP key at the measurement mode to enter record query mode.

INPUT RECORD START NUMBER
0 1 0 3 0 0

Press UP/DOWN and SHIFT key to input record number then press ENTER key enter or press MODE key exit.

Display ppm record at record

RECORD 0020300		
15-08-14	00100	ppm
21:20:49	025.0	°C
15-08-14	00100	ppm
21:20:59	025.0	°C
15-08-14	00110	ppm
21:21:09	025.0	°C
15-08-14	00110	ppm
21:21:19	025.0	°C
15-08-14	00100	ppm
21:21:29	025.0	°C

Display ppm record at XY chart

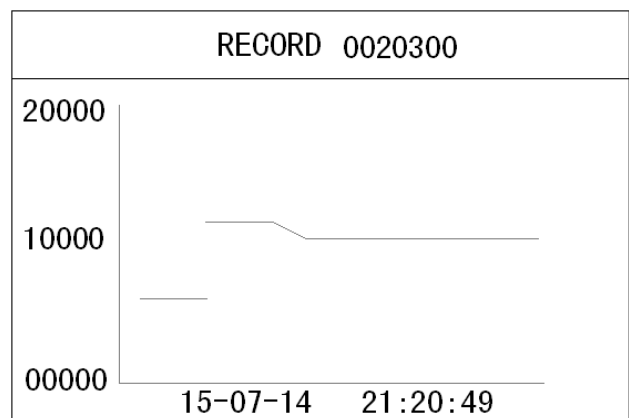

ION Calibration

Press MODE key to enter the password menu and then press UP/DOWN/SHIFT key to input password 1100 then press ENTER will enter to calibration mode or press MODE key to exit. If no key is be pressed and over 10 minutes then it will go back to measurement mode.

PASSWORD
0 0 0 0

PASSWORD
1 1 0 0

Manu

CALIBRATION
<input checked="" type="checkbox"/> Calibration <input type="checkbox"/> Reset Parameters

Press UP/DOWN key to select the functions and then press ENTER key to enter.

1. Calibration: calibrate the ppm
2. Reset parameters: reset all of the calibrated parameters to default.

Notice:

If the electrode efficiency is lower than 80%, user should check the electrode if aged, user

should Replace the new electrode.

Calibration

CALIBRATION	
0 1 0 0	2 3 0. 0 mV 2 5. 0 °C
Input buffer and press ENTER	

1. Put the electrode to the first buffer.
2. Press UP/DOWN key to input the correct buffer and then press ENTER to start calibration.
3. User can press ENTER to go to next when the reading is stable.
4. Display the mV on the right side.
5. If the mV is over +/-900mV or temperature is over 0.0-60.0°C then it will display error message on the button of LCD.

Slope calibration

CALIBRATION	
0 1 0 0 0	2 9 0. 0 mV 2 5. 0 °C
Input buffer and press ENTER	

1. Put the electrode to the second buffer.
2. Press UP/DOWN key to input the correct buffer and then press ENTER to start calibration.
3. User can press ENTER to go to next when the reading is stable.
4. Display the idea mV on the right side.
5. If the mV is over +/-1000mV or temperature is over 0.0-60.0°C then it will display error message on the button of LCD.

Display efficiency

校正	
0 1 0 0 0	2 9 0. 0 mV 2 5. 0 °C
EFFICIENCY = 97.3 %	

If the efficiency is lower than 80%, that means the electrode is aged user should Replace the new electrode.

If the efficiency is lower than 50% then the calibration is invalid.

Reset parameters

RESET PARAMETERS
RESET

This will reset all of the calibrated parameters to default.

Default

ION 20.00mA corresponding	100	ppm	range: 100 to 20000
ION 4.00mA corresponding	0	ppm	range: 0 to 19900 difference : 100
Temp. 20.00mA corresponding	100.0	°C	range: 0.0 to 130
Temp. 4.00mA corresponding	0.0	°C	range: -10.0 to 120.0 difference : 10.0
Current 1 output offset	0.00	mA	range: +/- 1.00
Current 2 output offset	0.00	mA	range: +/- 1.00
Current 1 filter	0	second	range: 0 to 120
Current 2 filter	0	second	range: 0 to 120
Current 1 fixed output	4.00	mA	range: 4.00 to 20.00
Current 2 fixed output	4.00	mA	range: 4.00 to 20.00
Current 1 HOLD type	fixed		range: fixed/last
Current 2 HOLD type	fixed		range: fixed/last
Relay 1 ION close S.P.	100	ppm	range: 0 to 20000
Relay 1 ION open S.P.	10	ppm	range: 0 to 20000 difference : 1
Relay 1 delay time	0	second	range: 0 to 120
Relay 2 ION close S.P.	10	ppm	range: 0 to 20000
Relay 2 ION open S.P.	100	ppm	range: 0 to 20000 difference : 1
Relay 2 delay time	0	second	range: 0 to 120
Relay 3 period time	1.0	hour	range: 0 to 1000.0
Relay 3 clean time	10	second	range: 0 to 1000
Relay 3 delay time	0		range: 0 to 120
Relay 3 function	error alarm		range: clean/period alarm/ error alarm
Save time	60	second	range: 5 to 120
ID address	1		range: 1 to 255
Baudrate	9600		range: 9600,19200,38400
ION offset	0	ppm	range: +/- 100
Temp. Offset	0.0	°C	range: +/- 5.0
Manual Temp. for measurement	25.0	°C	range: -10.0 to 130.0
Manual Temp. for calibration	25.0	°C	range: 0.0 to 60.0
Language	English		range: English/traditional Chinese /simple Chinese
Filter	1		range: 0 to 10
Temp. compensation	MTC		range: ATC/MTC

Temp. probe	Pt1000	range: Pt1000, NTC10K
Record type	record	range: record/XY chart

Password

Press MODE key

1100:Calibration mode

1200:Setting mode

If no key is be pressed and over 10 minutes then it will go back to measurement mode.

Error code

Error 01	memory error
Error 02	reading is over maximum
Error 03	reading is under minimum
Error 04	temperature is over maximum
Error 05	temperature is under minimum
Error 06	current 1 output is over 20.5 mA,the maximum is 22.00mA
Error 07	current 1 output is under 3.8 mA, the minimum is 3.5mA
Error 08	current 2 output is over 20.5 mA,the maximum is 22.00mA
Error 09	current 2 output is under 3.8 mA, the minimum is 3.5mA
Error 10	record error
Error 11	ADC damage
Error 99	default parameters lost

RS485 command

The instrument use the standard Modbus-RTU protocol, all of the data are word type(2 bytes), the range is -32767~32767 ,16 system.

PC command:

	ID address	command	Start address	Data number	CRC16
length	1 byte	1byte	2 byte	2 byte	2 byte
Ex.	0x01	0x03	0x0001	0x0001	0xD5CA

Instrument response:

	ID address	command	Data number	data	CRC16
length	1 byte	1 byte	1byte	N byte	2 byte

Ex.	0x01	0x03	0x02	0x02 0xBC	0xB895
-----	------	------	------	-----------	--------

If response is 01,the command is wrong.
 If response is 02,the address is not correct.
 If response is 03,data number is not correct.

command 03: read the settings
 command 04: read the readings

04:definition

address

(00)	0x00	ION reading	reading:X 1
(01)	0x01	ION current	reading:X 0.01
(02)	0x02	Temperature	reading:X 0.1
(03)	0x03	Temperature current	reading:X 0.01
(04)	0x04	Error code	reading:X 1
(05)	0x05		
(06)	0x06		
(07)	0x07		
(08)	0x08		
(09)	0x09	Model type	fix to 4

03:definition

Address

(00)	0x00	ION 20.00mA corresponding	reading:X 0.01
(01)	0x01	ION 4.00mA corresponding	reading:X 0.01
(02)	0x02	Temp. 20.00mA corresponding	reading:X 0.1
(03)	0x03	Temp. 4.00mA corresponding	reading:X 0.1
(04)	0x04	Current 1 offset	reading:X0.01
(05)	0x05	Current 2 offset	reading:X0.01
(06)	0x06	Current 1 filter	reading:X1
(07)	0x07	Current 2 filter	reading:X1
(08)	0x08	Current 1 fixed current	reading:X0.01
(09)	0x09	Current 2 fixed current	reading:X0.01
(10)	0x0A	Current 1 HOLD type	reading:X1 0=fixed,1=last
(11)	0x0B	Current 2 HOLD type	reading:X1 0=fixed,1=last
(12)	0x0C	Relay1 ION close S.P.	reading:X1
(13)	0x0D	Relay1 ION open S.P.	reading:X1
(14)	0x0E	Relay1 delay time	reading:X1
(15)	0x0F	Relay2 ION close S.P.	reading:X1

(16)	0x10	Relay2 ION open S.P.	reading:X1	
(17)	0x11	Relay2 delay time	reading:X1	
(18)	0x12	Relay3 clean period	reading:X0.1	
(19)	0x13	Relay3 clean time	reading:X1	
(20)	0x14	Relay3 delay time	reading:X1	
(21)	0x15	Relay3 function	reading:X1	0:clean,1:period alarm ,2:Error alarm
(22)	0x16	Record saving time	reading:X1	
(23)	0x17	ION offset	reading:X1	
(24)	0x18	Temp. offset	reading:X0.1	
(25)	0x19	Manual temp. for measurement	reading:X0.1	
(26)	0x1A	Manual temp. for calibration	reading:X0.1	
(27)	0x1B	Temp. compensation	reading:X1	0=Auto,1=manual
(28)	0x1C	Temp. probe	reading:X1	0=Pt1000,1=NTC10K
(29)	0x1D	Language	reading:X1	0=English ,1=traditional Chinese,2=simple Chinese
(30)	0x1E	Filter	reading:X1	